

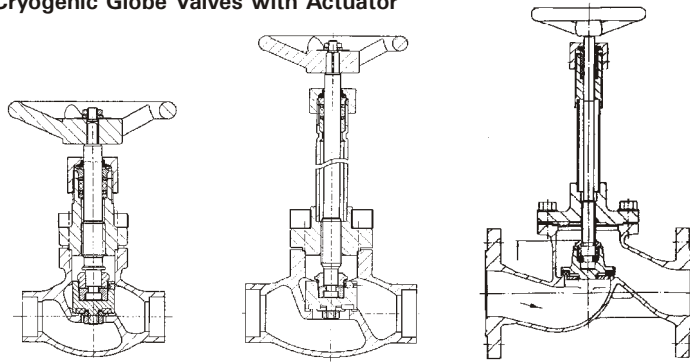

Cryogenic Globe Valves with Gland Packing
Cryogenic Globe Valves with Actuator



Changeover Valves, Divertors

Check Valves, Strainer

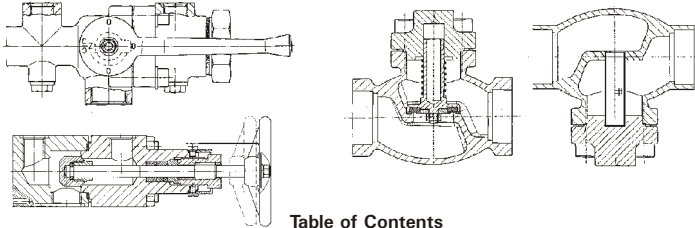

Table of Contents

1.0 General Information on Operating Instructions.....	2	4.2 Operation.....	3
2.0 Notes on Possible Dangers.....	2	4.3 Technical Data.....	3
2.1 Significance of Symbols.....	2	4.4 Marking.....	3
2.2 Safety Related Definitions.....	2	5.0 Installation.....	3
2.3 Qualified Personnel.....	2	5.1 Basic Notes on Installation.....	3
3.0 Handling.....	2	5.2 General Notes on Installation.....	3
3.1 Storage.....	2	6.0 Notes on danger during Installation, Operation and Maintenance.....	4
3.2 Transport.....	2	7.0 Operation.....	4
3.3 Handling before Installation.....	2	8.0 Maintenance and Repairs.....	4
4.0 Description.....	3	9.0 Dismantling the Valve.....	4
4.1 Scope of Application.....	3	10.0 Warranty.....	4

Operating and Installation Instructions

1.0 General Information on Operating Instructions

These operating instructions contain the necessary information to install and operate the valve both safely and effectively.

If problems arise which cannot be solved with the aid of these operating instructions, please contact the supplier/manufacturer for further information. These operating instructions comply with the applicable EN safety standards as well as regulations and codes of practice applicable in the Federal Republic of Germany. If the valve is used outside the Federal Republic of Germany, the operator or the person responsible for the system design must ensure that valid national codes of practice are complied with. The manufacturer reserves all rights to implement technical modifications and improvements at any time. The use of these operating instructions assumes the user is qualified as described under Section 2.3 "Qualified Personnel".

The operating personnel must be instructed in accordance with the operating instructions.

2.0 Notes on Possible Dangers

2.1 Significance of Symbols

Warning of general danger

2.2 Safety Related Definitions

The signal definitions DANGER, WARNING, CAUTION and NOTE are used in these operating instructions as indications for particular hazards or for information requiring special signs.

DANGER means that if the relevant information is disregarded, there is a danger of fatal injury and / or considerable damage to property can occur.

WARNING means that if the relevant information is disregarded, there is a danger of serious injury and / or damage to property can occur.

CAUTION means that if the relevant information is disregarded, there is a danger of serious injury and / or damage to property can occur.

NOTE means that particular attention must be paid to certain technical aspects.

All other information not specifically emphasised such as transport, installation, operating and maintenance instructions as well as technical data (in the operating instructions, product documentation and on the device itself) must also be complied with to the fullest extent in order to avoid faults which in turn can cause serious injury to persons or damage property.

2.3 Qualified Personnel

The term "qualified personnel" relates to persons who are familiar with the installation, assembly, start up and operation of the product and have the qualification corresponding to their responsibilities. Such as: Instruction and awareness to comply with all operational, regional and in-company regulations and requirements; Training or instruction in accordance with safety technology standards with regard to the upkeep and use of appropriate safety and work protection equipment; First aid training, etc. (see TRB 700)

3.0 Handling

3.1 Storage

- Storage temperature -20°C to +65°C dry, free of dirt.
- A desiccant or heating to prevent condensation is necessary in damp rooms.

3.2 Transport

- Transport temperature -20°C to +65°C.
- Protect against external force (impact, vibration etc.).

3.3 Handling before Installation

- If flange covers are fitted, remove shortly before installation.
- Protect against atmospheric conditions e.g. wetness (use a desiccant)!
- Correct handling protects against damage.

The Valves are cleaned and degreased for oxygen. Please keep sealed in the plastic bag until use. All tools are to clean before starting the installation or work.

Operating and Installation Instructions

4.0 Description

4.1 Scope of Application

Globe Valves are suitable to "shut or reduce the flow of Medium". Changeover Valves will be used for the installation of equipment for protection against excessive pressure acc. to BetrSichV §17 Anhang 5 Nr. 12. The operational field of the valve is under the responsibility of the qualified engineer. Pay attention to special markings of the Valve like:

- permitted medium: oxygen, nitrogen, argon, krypton, carbon dioxide, dinitrogen monoxide, chlorine trifluoromethan, trifluoromethan, carbon oxide, methan, ethan and ethylen
- Valves for oxygen (O₂) are durable marked with "O₂".
- please contact the manufacturer for valves for special medium, which require or exclude specific materials

4.2 Operation

The Globe Valves will be closed by turning the handwheel right (clockwise), the typical disc/seat function. Tools to increase the torque of the handwheel are not allowed. Detailed installation and operation instructions for Globe Valves with pneumatic or electric actuators are included to the valve. Changeover Valves will be operated by turning the handwheel/lever. At the end positions one outlet (right or left) is open. A simultaneous closing of both outlets is not possible.

4.3 Technical Data

- Main dimensions of the valve - see data sheet of catalogue
- Pressure-Temperature-rates - see data sheet of catalogue
- Valves with welding or brazing end connections - see data sheet of catalogue

4.4 Marking

CE - Marking of Valves
only valid for valves greater then size DN 25!

- CE - mark
- 0045 notified body
- PN 50 maximum working pressure
- 08/01 Year of Manufacturing
- XXXX Serial Number of the Valve
- Trademark of Manufacturer

Marking of Valves equal or smaller size DN 25.

- Label Sound Engineering Practice acc. to art. 3.3 of PED 97/23/EC
- PN 50 maximum working pressure
- 08/01 Year of Manufacturing
- XXXX Serial Number of the Valve
- Trademark of Manufacturer

5.0 Installation

5.1 Basic Notes on Installation

- Attention to the fitting position concerning flow direction
- fitting position concerning stem direction for cryogenic valves not more then 65° to the vertical line
- Priority position: Stem vertical
- **Dismantling of Topwork for Valves with welding or soldering end connection** before the welding or soldering process starts, Instructions for reassembling of the Topwork and replacement bonnet gaskets (2 pieces) are attached to the Valve
- Seals between flanges must be centered, flanges must be correct dimensioned
- installation in such a way that no inadmissible static, dynamic or thermal loads can be transmitted to the valve
- The valve is no fixing point and must be supported by the piping construction
- Valves must be protected against soiling, especially during construction work - Note: cleaned for oxygen (O₂)
- thermal expansion of the piping must be balanced by compensators
- No paintwork is allowed
- fitting position of Globe/Check Valves is general vertical and the medium flow must be from under the disc. Should the valves be installed in another fitting position a closing spring must be inside the valve.
- installation of Check Valves acc. to the flow direction marking on the body that the medium flow come from under the disc
- installation of Strainer Valves acc. to the flow direction marking on the body that contaminations of the medium will be collected inside the mesh

5.2 General Notes on Installation

The following points should be taken into account besides the basic notes on installation:

- Visual checking of marking (see 4.3) concerning application and set pressure
- Visual checking concerning outer damage. Damaged valves should be not installed
- Remove protecting cap if present
- The space inside the valve and the pressure vessel must be free of any foreign products.
- Care must be taken should the components become hot or cold during the installation of the valve. Operating personnel must be instructed

Operating and Installation Instructions

- When installing valves with threaded connections, use metal or plastic seal washers only acc. to DIN 7603 (O₂ - suitability is to notice!)

CAUTION: Seal materials such as seal tape or liquid seal material should not be used as this type of material can break off and enter the valve causing it to leak.

- Only use suitable tools (O₂ - suitability is to notice!)

CAUTION: The torque must be correct to avoid any damages.

6.0 Notes on danger during Installation, Operation and Maintenance

A safe operation of the valve is only guaranteed, if the installation, first operation and maintenance will be carried out by qualified personnel (see point 2.3) in compliance with these operating and installation instructions. Furthermore pay attention to the general installation and safety rules and standards for piping resp. facility construction. A professional use of tools and safety equipment must be guaranteed during installation. During all work on and with the valve follow the operating and installation instructions of the valve. A non-compliance with these instructions can be followed by fatal injury and / or considerable damage.

7.0 Operation

- before first operation the information of material, pressure, temperature and flow direction must be checked acc. to the installation plan of the piping system.
- the TRB 700 must be observed
- Residues in the piping and in Valves (dirt, bead of perspiration, etc.) conduct inevitable to leakage

Before first operation of a new constructed facility or a refurbished facility the following must be checked and examined:

- the installation work must be completely finished!
- Starting of operation can only be carried out by qualified personnel (see point 2.3)
- the correct function and operation position of the valve
- Installation resp. re-operation of existing safety equipment

8.0 Maintenance

Maintenance and maintenance-intervals have to be defined by the operator according to the service conditions, see TRB 700.

If valves with Gland packing are leaking on the gland packing (Pos.1), please torque the gland screw (2) until tightness.

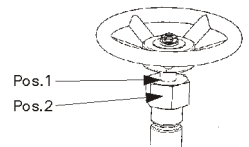

Repairs on valves can only be carried out by company HEROSE or authorized HEROSE workshops, revied by official licenced authorities.

9.0 Dismantling the Valve

- The following points must be observed beside the general principal rules and TRB 700 governing the assembly work:
- pressureless pipe system
- medium and valve must be cool at ambient temperature
- plant must be drained
- purge piping system in case of aggressive or caustic media
- have assembly work performed only by qualified personnel (see point 2.3)

10.0 Warranty

The extent and period of warranty cover are specified in the "sales conditions of HEROSE GMBH" valid at the time of delivery or, by notice in supplied documentation, in the contract of sale itself. No warranty claims can be made for any damage caused as the result of incorrect handling, disregard of operating and installation instructions, accident prevention regulations, EN, DIN, VDE standards and other applicable codes of practice. No warranty claims can be made for any damage caused as the result wrong installation or disregard of datasheet informations. Maintenance, Installation of foreign components in valves and modifications of design are excluded of period of warranty.